

EMC Test Report
For
Noor Al Hayat Computer Tr LLC

Power Supply

Model: Tortox BX600,Tortox BX700

Prepared For : Noor Al Hayat Computer Tr LLC

Mohammed Al mulla Tower,Office No. 1007,Near Ansar Mall,
Sharjah, UAE

Prepared By : Beide (Shenzhen) Product Service Limited

China: 6F, Bldg E, Hourui 3rd Ind Zone, Xixiang, Bao'an Dist,
Shenzhen, China

Report Number: B-E180818716

Date of Test: Aug. 01-06, 2018

Date of Report: Aug. 07, 2018

TABLE OF CONTENT

Description	Page
Test Report Declaration	
1. TEST RESULTS SUMMARY	5
2. GENERAL INFORMATION	6
2.1. Report Information	6
2.2. Description of Device (EUT).....	6
2.3. Test Facility	7
2.4. Test Uncertainty.....	7
2.5. Test Condition	7
2.6. Test Conditions.....	7
2.7. Performance Criterion	7
3. TEST INSTRUMENT USED	8
3.1. For Conducted Emission Test.....	8
3.2. For Radiation Emission Test	8
3.3. For Harmonic / Flicker Test	8
3.4. For Electrostatic Discharge Immunity Test.....	8
3.5. For Radio Frequency Electromagnetic Field.....	9
3.6. For Electrical Fast Transient/Burst Test	9
3.7. For Surge Test.....	9
3.8. For Injected Currents Susceptibility Test	9
3.9. For Voltage Dips and Interruptions Test	9
4. POWER LINE CONDUCTED EMISSION TEST	10
4.1. Block Diagram of Test Setup	10
4.2. Test Standard	10
4.3. Power Line Conducted Emission Limit.....	10
4.4. EUT Configuration on Test	10
4.5. Operating Condition of EUT	11
4.6. Test Procedure	11
4.7. Power Line Conducted Emission Test Results	11
5. RADIATION EMISSION TEST	12
5.1. Block Diagram of Test Setup	12
5.2. Test Standard	12
5.3. Radiation Emission Limit	12
5.4. EUT Configuration on Test	12
5.5. Operating Condition of EUT	13
5.6. Test Procedure	13
5.7. Radiation Emission Test Results	13
6. HARMONIC CURRENT EMISSION TEST	14
6.1. Block Diagram of Test Setup	14
6.2. Test Standard	14
6.3. Operating Condition of EUT	14
6.4. Test Results.....	14
7. VOLTAGE FLUCTUATIONS & FLICKER TEST	15
7.1. Block Diagram of Test Setup	15
7.2. Test Standard	15
7.3. Operating Condition of EUT	15
7.4. Test Results.....	15
8. ELECTROSTATIC DISCHARGE TEST	16
8.1. Block Diagram of Test Setup	16
8.2. Test Standard	16

8.3. Severity level and Performance criterion.....	17
8.4. EUT Configuration on Test	17
8.5. Operating Condition of EUT	17
8.6. Test Procedure	17
8.7. Test Results.....	17
9. RF FIELD STRENGTH SUSCEPTIBILITY TEST	19
9.1. Block Diagram of Test Setup	19
9.2. Test Standard	19
9.3. Severity level and Performance criterion.....	19
9.4. EUT Configuration on Test	19
9.5. Operating Condition of EUT	20
9.6. Test Procedure	20
9.7. Test Results.....	20
10. ELECTRICAL FAST TRANSIENT/BURST TEST	22
10.1. Block Diagram of Test Setup.....	22
10.2. Test Standard	22
10.4. EUT Configuration on Test	23
10.5. Operating Condition of EUT	23
10.6. Test Procedure	23
10.7. Test Results.....	23
11. SURGE TEST	25
11.1. Block Diagram of Test Setup.....	25
11.2. Test Standard	25
11.3. Severity level and Performance criterion.....	25
11.4. EUT Configuration on Test	26
11.5. Operating Condition of EUT	26
11.6. Test Procedure	26
11.7. Test Results.....	26
12. INJECTED CURRENTS SUSCEPTIBILITY TEST	28
12.1. Block Diagram of Test Setup.....	28
12.2. Test Standard	28
12.3. Severity Levels and Performance Criterion.....	28
12.4. EUT Configuration on Test	29
12.5. Operating Condition of EUT	29
12.6. Test Procedure	29
12.7. Test Results.....	29
13. VOLTAGE DIPS AND INTERRUPTIONS TEST	31
13.1. Block Diagram of Test Setup.....	31
13.2. Test Standard	31
13.3. Severity level and Performance criterion.....	31
13.4. EUT Configuration	32
13.5. Operating Condition of EUT	32
13.6. Test Procedure	32
13.7. Test Results.....	32
APPENDIX I (TEST DATA)	(4 pages)
APPENDIX II (EUT PHOTOS)	(1 page)

TEST REPORT DECLARATION

Applicant : Noor Al Hayat Computer Tr LLC
Address : Mohammed Al mulla Tower,Office No. 1007,Near Ansar Mall,
Sharjah, UAE
Client No. : 09716942
Manufacturer : Guangzhou Aojie Science & Technology Co.,Ltd.
Address : No.18 Gaozeng Industrial Park,Fanghua Road East, Renhe,
Baiyun, Guangzhou,Guangdong,China
EUT Description : Power Supply
Model No. : Tortox BX600,Tortox BX700
Remark : Use Tortox BX600 do all the tests.
Technical Data : 110-240V~,47-63Hz,600W

Test Procedure Used:

EN 55032:2015;EN 61000-3-2:2014;EN 61000-3-3:2013;
EN 55024:2010+A1:2015(EN 61000-4-2:2009, EN 61000-4-3:2006+A2:2010,
EN 61000-4-4:2012, EN 61000-4-5:2014,
EN 61000-4-6:2014, EN 61000-4-11:2004)

The device described above is tested by Beide (Shenzhen) Product Service Limited to determine the maximum emission levels emanating from the device, the severe levels which the device can endure and EUT's performance criterion. The test results are contained in this test report. Beide (Shenzhen) Product Service Limited is assumed of full responsibility for the accuracy and completeness of these tests.

This report applies to above tested sample only and shall not be reproduced in part without written approval of Beide (Shenzhen) Product Service Limited.

Date of Test : Aug. 01-06, 2018

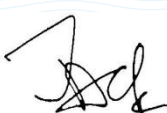
Prepared by : 

(Jack)

Checked by : 

(Vivian)

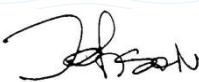
Approved by : 

(Johnson)



1. TEST RESULTS SUMMARY

Test Results Summary

	Test Items	Test Results
1	Conducted Disturbance Test	PASS
2	Radiation Emission Test	PASS
3	Harmonic Current Emission Test	PASS
4	Voltage Fluctuations & Flicker Test	PASS
5	Electrostatic Discharge Test	PASS
6	Radio Frequency Electromagnetic Field	PASS
7	Electrical Fast Transient/Burst Test	PASS
8	Surge Test	PASS
9	Injected Currents Susceptibility Test	PASS
10	Voltage Dips And Interruptions Test	PASS

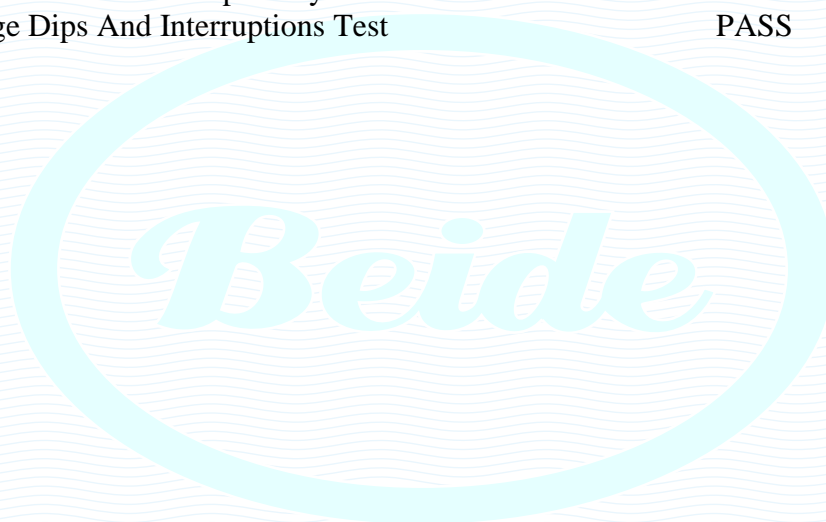

2.GENERAL INFORMATION

2.1.Report Information

2.1.1. This report is not a certificate of quality, it only applies to the sample of the specific product/equipment given at the time of its testing. The results are not used to indicate or imply that they are application to the similar items. In addition, such results must not be used to indicate or imply that BEIDE approves recommends or endorses the manufacture, supplier or use of such product/equipment, or that BEIDE in any way guarantees the later performance of the product/equipment.

2.1.2. The sample/s mentioned in this report is/are supplied by applicant, BEIDE therefore assumes no responsibility for the accuracy of information on the brand names, model number, origin of manufacture or any information supplied.

Additional copies of the report are available to the applicant at an additional fee. No third part can obtain a copy of this report through BEIDE, unless the applicant has authorized BEIDE in writing to do so.

2.2.Description of Device (EUT)

Description : Power Supply

Number Model : Tortox BX600

Applicant : Noor Al Hayat Computer Tr LLC
Mohammed Al mulla Tower,Office No. 1007,Near Ansar Mall,
Sharjah, UAE

Manufacturer : Guangzhou Aojie Science & Technology Co.,Ltd.
No.18 Gaozeng Industrial Park,Fanghua Road East, Renhe, Baiyun,
Guangzhou,Guangdong,China

2.3. Test Facility

Site Description

Tested by : Beide (Shenzhen) Product Service Limited

Site Location : 6F, Bldg E, Hourui 3rd Ind Zone, Xixiang, Bao' an Dist, Shenzhen, China

2.4. Test Uncertainty

Conducted Emission Uncertainty = $\pm 2.66\text{dB}$

Radiated Emission Uncertainty = $\pm 4.26\text{dB}$

2.5. Test Condition

Test Mode: ON

2.6. Test Conditions

Temperature: 22°C-28°C

Relative Humidity: 45%-68%

2.7. Performance Criterion

Performance criterion **A**:

The equipment shall continue to operate as intended during the test.

No change of actual operating state (for example change of channel) is allowed as a result of the application of the test.

Multifunction equipment shall for each function meet the relevant requirements.

Evaluation is carried out for audio and video functions.

Performance criterion **B**:

The equipment shall continue to operate as intended after the test. No loss of function is allowed after the test when the apparatus is used as intended. But failures which are recovered automatically but which cause temporary delay in processing, are permissible. No change of actual operating state for example change of channel or stored data and settings is allowed as a result of the application of the test. During the test, degradation of performance is allowed.

3. TEST INSTRUMENT USED

3.1. For Conducted Emission Test

Item	Equipment	Manufacturer	Model No.	Serial No.	Last Cal.	Cal. Interval
1.	Spectrum Analyzer	Aglient	E4402B-ESA	US1192821	2018.07.18	1 Year
2.	EMI Test Receiver	ROHDE&SCHWARZ	ESPI	101206	2018.07.18	1 Year
3.	L.I.S.N.	SCHWARZBECK	NSLK8126	8126-224	2018.07.18	1 Year
4.	L.I.S.N.	EMCO	3825/2	11977C	2018.07.18	1 Year

3.2. For Radiation Emission Test

Item	Equipment	Manufacturer	Model No.	Serial No.	Last Cal.	Cal. Interval
1.	Spectrum Analyzer	Rohde&schwarz	FSEA20	DE25181	2018.07.18	1 Year
2.	Positioning Controller	C&C	CC-C-1F	N/A	2018.07.18	1 Year
3.	Trilog Broadband Antenna	Schwarzbeck	VULB9163	9163-333	2018.07.18	1 Year
4.	Horn Antenna	Schwarzbeck	BBHX9120	9120-426	2018.07.18	1 Year
5.	RF Switch	EM	EMSW18	SW060023	2018.07.18	1 Year
6.	Amplifier	Agilent	8447F	3113A06717	2018.07.18	1 Year
7.	Coaxial Cable	Schwarzbeck	AK9513	9513-10	2018.07.18	1 Year
8.	EMI Test Receiver	Rohde&schwarz	ESPI	25498514	2018.07.18	1 Year

3.3. For Harmonic / Flicker Test

Item	Equipment	Manufacturer	Model No.	Serial No.	Last Cal.	Cal. Interval
1.	Signal Conditioning Unit	SCHAFFNER	CCN1000-1	23980/7	2018.07.18	1 Year
2.	Signal Phase Impedance Network	SCHAFFNER	INA2152	0929-2	2018.07.18	1 Year
3.	5KVA AC Power Source	SCHAFFNER	NSG1007	2983332	2018.07.18	1 Year

3.4. For Electrostatic Discharge Immunity Test

Item	Equipment	Manufacturer	Model No.	Serial No.	Last Cal.	Cal. Interval
1.	ESD Tester	Noiseken	ESS-200AX	0223	2018.07.18	1 Year

3.5.For Radio Frequency Electromagnetic Field

Item	Equipment	Manufacturer	Model No.	Serial No.	Last Cal.	Cal. Interval
1.	Signal Generator	IFR	2032	203002/100	2018.07.18	1 Year
2.	Amplifier	A&R	150W1000	301584	2018.07.18	1 Year
3.	Dual Directional Coupler	A&R	DC6080	301508	2018.07.18	1 Year
4.	Power Head	A&R	PH2000	301193	2018.07.18	1 Year
5.	Power Meter	A&R	PM2002	302799	2018.07.18	1 Year
6.	Field Monitor	A&R	FM5004	300329	2018.07.18	1 Year
7.	Field Probe	A&R	FP5000	300221	2018.07.18	1 Year

3.6.For Electrical Fast Transient/Burst Test

Item	Equipment	Manufacturer	Model No.	Serial No.	Last Cal.	Cal. Interval
1.	Ultra Compact Simulator	EM TEST	UCS500M6	0500-19	2018.07.18	1 Year

3.7.For Surge Test

Item	Equipment	Manufacturer	Model No.	Serial No.	Last Cal.	Cal. Interval
1.	Surge Tester	HAEFELY	PSURGE4.1	080107-04	2018.07.18	1 Year

3.8.For Injected Currents Susceptibility Test

Item	Equipment	Manufacturer	Model No.	Serial No.	Last Cal.	Cal. Interval
1.	Signal Generator	IFR	2032	203002/100	2018.07.18	1 Year
2.	Amplifier	A&R	150W1000	301584	2018.07.18	NCR

3.9.For Voltage Dips and Interruptions Test

Item	Equipment	Manufacturer	Model No.	Serial No.	Last Cal.	Cal. Interval
1.	Dips Tester	HEAFELY	PLINE 1610	083732-18	2018.07.18	1 Year

4. POWER LINE CONDUCTED EMISSION TEST

4.1. Block Diagram of Test Setup

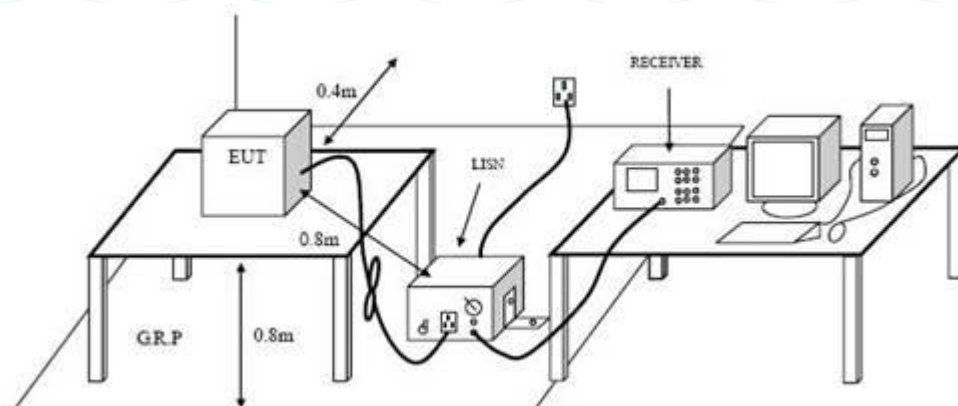

4.2. Test Standard

EN 55032:2015

4.3. Power Line Conducted Emission Limit

Frequency MHz	Limits dB(μ V)	
	Quasi-peak Level	Average Level
0.15 ~ 0.50	56 ~ 66*	46 ~ 56*
0.50 ~ 5.00	56	46
5.00 ~ 30.00	60	50

Notes: 1. *Decreasing linearly with logarithm of frequency.
2. The lower limit shall apply at the transition frequencies.

4.4. EUT Configuration on Test

The following equipments are installed on conducted emission test to meet the test requirement and operating in a manner, which tends to maximize its emission characteristics in a normal application.

4.4.1 Power Supply

Model Number : Tortox BX600
Manufacturer : Guangzhou Aojie Science & Technology Co.,Ltd.

4.5.Operating Condition of EUT

- 4.5.1. Setup the EUT and simulators as shown in Section 4.1.
- 4.5.2. Turn on the power of all equipments.
- 4.5.3. Let the EUT work in test mode (ON) and test it.

4.6.Test Procedure

The EUT is put on the ground and connected to the AC mains through an Artificial Mains Network (L.I.S.N.). This provided 50ohm-coupling impedance for the tested equipments. Both sides of AC line are checked to find out the maximum conducted emission levels according to the EN 55032 regulations during conducted emission test.

The bandwidth of the test receiver (R&S Test Receiver ESPI) is set at 10kHz.

The frequency range from 150 kHz to 30 MHz is investigated. The scanning waveform are attached within Appendix I.

4.7.Power Line Conducted Emission Test Results

PASS

Beide

5. RADIATION EMISSION TEST

5.1. Block Diagram of Test Setup

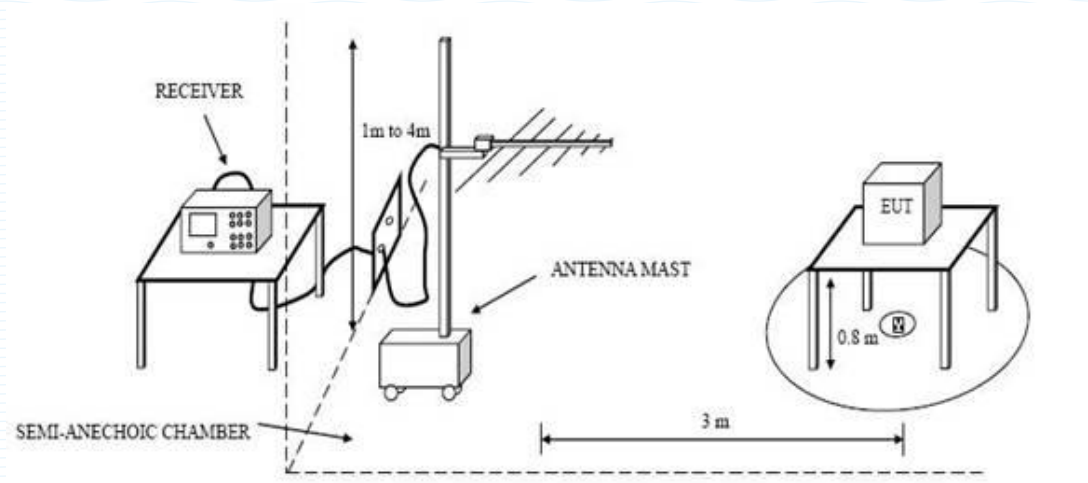

5.2. Test Standard

EN 55032:2015

5.3. Radiation Emission Limit

All emanations from a Class B computing devices or system, including any network of conductors and apparatus connected thereto, shall not exceed the level of field strengths specified below:

FREQUENCY (MHz)	DISTANCE (Meters)	FIELD STRENGTHS LIMITS (dB μ V/m)
30 ~ 230	3	40
230 ~ 1000	3	47

- Notes: 1. The tighter limit shall apply at the edge between two frequency bands.
2. Distance refers to the distance in meters between the measuring instrument antenna and the closed point of any part of the EUT.

5.4. EUT Configuration on Test

The test Class B regulations test method must be used to find the maximum emission during radiated emission test.

The configuration of EUT is same as used in Conducted Emission test. Please refer to Section 4.4.

5.5.Operating Condition of EUT

- 5.5.1. Setup the EUT as shown on Section 5.1.
- 5.5.2. Turn on the power of all equipments.
- 5.5.3. Let the EUT work in test mode (ON) and measure it and test it.

5.6.Test Procedure

The EUT is placed on a turn table which is 0.8 meter above ground. The turn table can rotate 360 degrees to determine the position of the maximum emission level. The EUT is set 3 meters away from the receiving antenna which is mounted on a antenna tower. The antenna can move up and down between 1 to 4 meters to find out the maximum emission level. Broadband antenna(calibrated by dipole antenna) are used as a receiving antenna. Both horizontal and vertical polarization of the antenna is set on test.

The bandwidth setting on the test receiver(R&S TEST RECEIVER ESPI) is 120kHz. The EUT is tested in Anechoic Chamber.

5.7.Radiation Emission Test Results

PASS

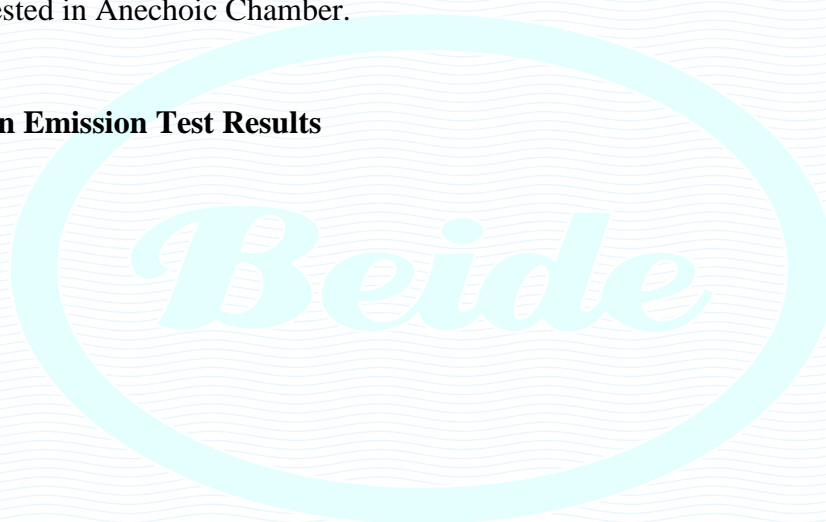

6.HARMONIC CURRENT EMISSION TEST

6.1.Block Diagram of Test Setup

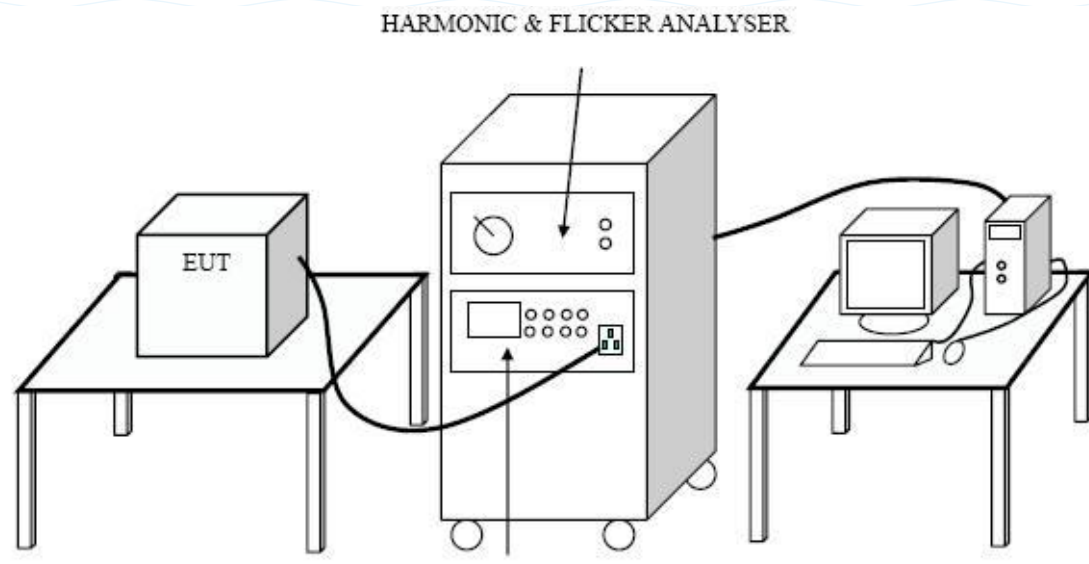

6.2.Test Standard

EN 61000-3-2: 2014, Class-A

6.3.Operating Condition of EUT

Same as Section 4.5 except the test set up replaced by Section 6.1.

6.4.Test Results

PASS

7.VOLTAGE FLUCTUATIONS & FLICKER TEST

7.1.Block Diagram of Test Setup

Same as Section 6.1.

7.2.Test Standard

EN 61000-3-3:2013

7.3.Operating Condition of EUT

Same as Section 4.5 except the test set up replaced by Section 7.1.

7.4.Test Results

PASS



8.ELECTROSTATIC DISCHARGE TEST

8.1.Block Diagram of Test Setup

8.1.1. Block Diagram of ESD Test Setup (Direct Discharge)

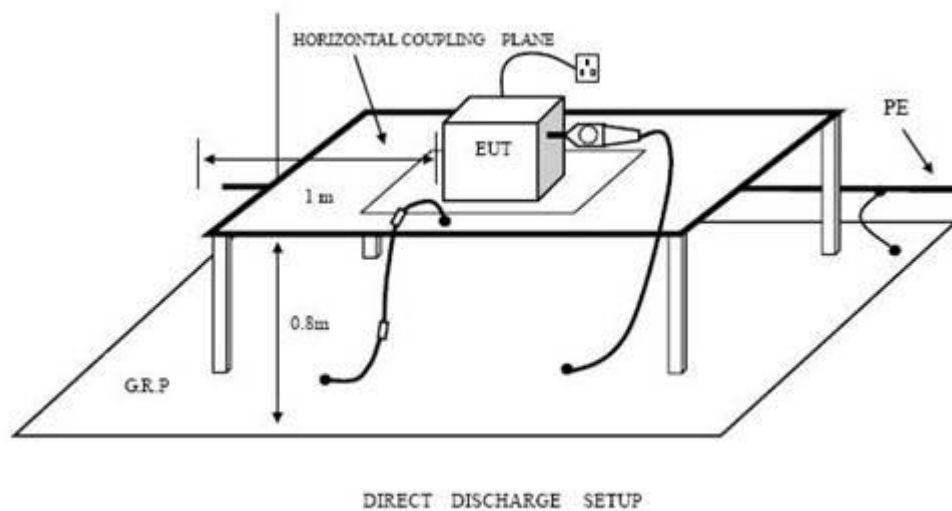

8.1.2. Block Diagram of ESD Test Setup (Indirect Discharge)

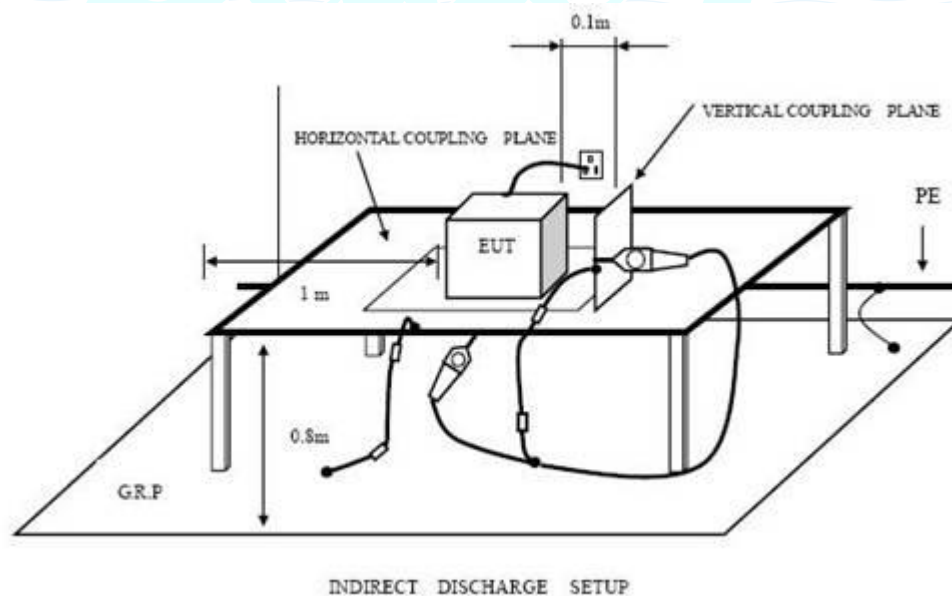

8.2.Test Standard

EN 55024:2010+A1:2015 (EN 61000-4-2:2009)

Severity Level 3 for Air Discharge at 8kV

Severity Level 2 for Contact Discharge at 4kV

8.3. Severity level and Performance criterion

8.3.1. Severity level

Level	Test Voltage Contact Discharge (kV)	Test Voltage Air Discharge (kV)
1.	2	2
2.	4	4
3.	6	8
4.	8	15
X.	Special	Special

Performance criterion: **B**

8.4. EUT Configuration on Test

The configuration of EUT is listed in Section 4.4.

8.5. Operating Condition of EUT

8.5.1. Setup the EUT as shown in Section 4.5. except the test set up replaced by section 8.1.

8.6. Test Procedure

8.6.1. Air Discharge:

This test is done on non-conductive surfaces. The round discharge tip of the discharge electrode shall be approached as fast as possible to touch the EUT.

After each discharge, the discharge electrode shall be removed from the EUT.

The generator is then re-triggered for a new single discharge and repeated 10 times for each pre-selected test point. This procedure shall be repeated until all the air discharge completed.

8.6.2. Contact Discharge:

All the procedure shall be same as Section 8.6.1 except that the tip of the discharge electrode shall touch the EUT before the discharge switch is operated.

8.7. Test Results

PASS

Please refer to the following page.

Electrostatic Discharge Test Results

Beide (Shenzhen) Product Service Limited

Date: Aug. 02, 2018

Applicant : Noor Al Hayat Computer Tr LLC	Test Date : Aug. 02, 2018
EUT : Power Supply	Temperature : 24°C
M/N : Tortox BX600	Humidity : 51%
Power Supply : AC 230V~, 50Hz	Test Mode : ON
Test Engineer : Jack	

Air Discharge: $\pm 8\text{kV}$ discharge. For each point positive 10 times and negative 10 times

Contact Discharge: $\pm 4\text{kV}$

Location		Kind A-Air Discharge C-Contact Discharge	Result
Surface	20 points	A	PASS
Slots	20 points	A	PASS
Plug	5 points	C	PASS
HCP	5 points	C	PASS
VCP	5 points	C	PASS

Discharge should be considered on Contact and Air and Horizontal Coupling Plane (HCP) and Vertical Coupling Plane (VCP).

Reviewer: _____

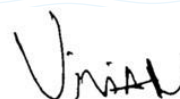

9. RF FIELD STRENGTH SUSCEPTIBILITY TEST

9.1. Block Diagram of Test Setup

9.1.1. Block diagram of Test Setup

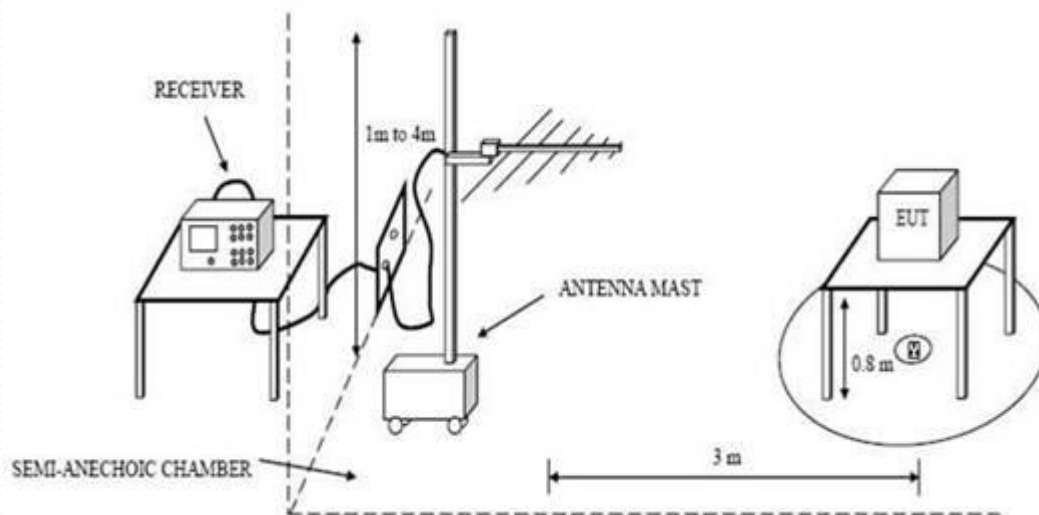

9.2. Test Standard

EN 55024:2010+A1:2015 (EN 61000-4-3:2006+A2:2010)
Severity Level 2 at 3 V/m

9.3. Severity level and Performance criterion

9.3.1. Severity level

Level	Field Strength V/m
1.	1
2.	3
3.	10
X.	Special

Performance criterion : **A**

9.4. EUT Configuration on Test

The configuration of EUT is listed in Section 4.4.

9.5. Operating Condition of EUT

Setup the EUT as shown in Section 9.1. The operating condition of EUT is listed in section 4.5.

9.6. Test Procedure

The EUT and its simulators are placed on a turn table which is 0.8 meter above the ground. The EUT is set 3 meters away from the transmitting antenna which is mounted on an antenna tower. Both horizontal and vertical polarization of the antenna are set on test. Each of the four sides of EUT must be faced this transmitting antenna and measured individually. In order to judge the EUT performance, a CCD camera is used to monitor the EUT. All the scanning conditions are as follows:

Condition of Test	Remarks
1. Fielded Strength	3 V/m (Severity Level 2)
2. Radiated Signal	Modulated
3. Scanning Frequency	80 - 1000 MHz
4. Sweeping time of radiated	0.0015 decade/s
5. Dwell Time	1 Sec.

9.7. Test Results

PASS

Please refer to the following page.

RF Field Strength Susceptibility Test Results

Beide (Shenzhen) Product Service Limited

Date: Aug. 02, 2018

Applicant : Noor Al Hayat Computer Tr LLC	Test Date : Aug. 02, 2018
EUT : Power Supply	Temperature : 24°C
M/N : Tortox BX600	Humidity : 53%
Power Supply : AC 230V~, 50Hz	Test Mode : ON
Test Engineer : Jack	Frequency Range : 80-1000MHz
Modulation: <input checked="" type="checkbox"/> AM <input type="checkbox"/> Pulse <input type="checkbox"/> none 1 kHz 80%	
Criterion : A	
Frequency Range: 80-1000 MHz	
Steps	1% 1%
	Horizontal Vertical
Front	Pass Pass
Right	Pass Pass
Rear	Pass Pass
Left	Pass Pass

Reviewer :

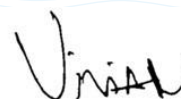

10. ELECTRICAL FAST TRANSIENT/BURST TEST

10.1. Block Diagram of Test Setup

10.1.1. Block diagram of Test Setup

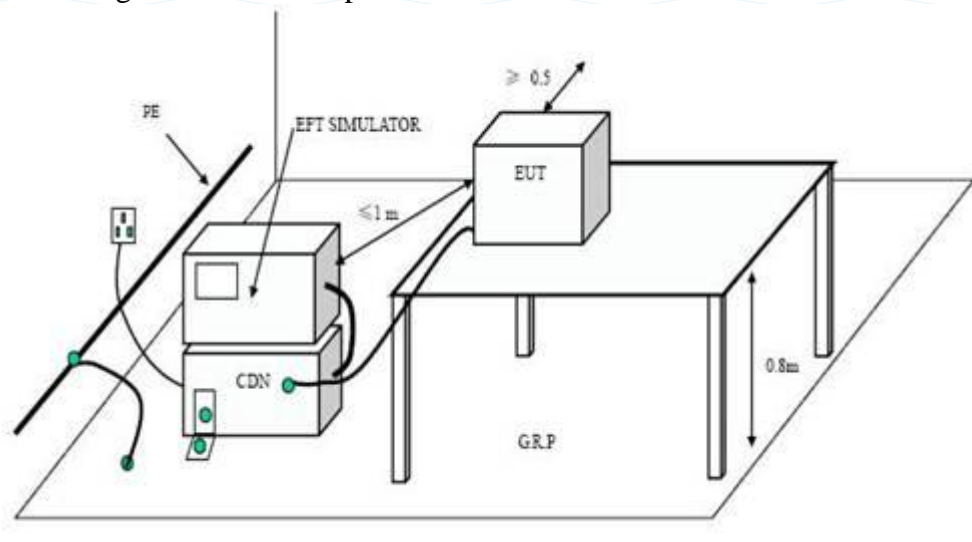

10.2. Test Standard

EN 55024:2010+A1:2015 (EN 61000-4-4:2012)
Severity Level 2 at 1kV

10.3. Severity level and Performance criterion

10.3.1. Severity level

Level	Open Circuit Output Test Voltage $\pm 10\%$	
	On Power Supply Lines	On I/O (Input/Output) Signal data and control lines
1.	0.5 kV	0.25 kV
2.	1 kV	0.5 kV
3.	2 kV	1 kV
4.	4 kV	2 kV
X	Special	Special

Performance criterion : **B**

10.4. EUT Configuration on Test

The configuration of EUT is listed in Section 4.4.

10.5. Operating Condition of EUT

Setup the EUT as shown in Section 10.1. The operating condition of EUT is listed in section 4.5.

10.6. Test Procedure

The EUT is put on the table which is 0.8 meter high above the ground reference plane which is a min 1m*1m metallic sheet with 0.65mm minimum thickness. This reference ground plane shall project beyond the EUT by at least 0.8m on all sides and the minimum distance between the EUT and all other conductive structure, except the ground plane beneath the EUT, shall be more than 0.5m.

10.6.1. For input and output AC power ports:

The EUT is connected to the power mains by using a coupling device which couples the EFT interference signal to AC power lines. Both polarities of the test voltage should be applied during compliance test and the duration of the test is 2 mins.

10.6.2. For signal lines and control lines ports:

It's unnecessary to test.

10.6.3. For DC output line ports:

It's unnecessary to test.

10.7. Test Results

PASS

Please refer to the following page.

Electrical Fast Transient/Burst Test Results

Beide (Shenzhen) Product Service Limited

Date: Aug. 02, 2018

Applicant	: Noor Al Hayat Computer Tr LLC	Test Date	: Aug. 02, 2018						
EUT	: Power Supply	Temperature	: 24°C						
M/N	: Tortox BX600	Humidity	: 53%						
Power Supply	: AC 230V~, 50Hz	Test Mode	: ON						
Test Engineer : Jack									
Inject Place : AC Mains									
Inject Line	Voltage kV	Inject Time(s)	Inject Method	Results	Inject Line	Voltage kV	Inject Time(s)	Inject Method	Results
L	±1	120	Direct	PASS					
N	±1	120	Direct	PASS					
L, N	±1	120	Direct	PASS					

Reviewer: _____

Vincent

11. SURGE TEST

11.1. Block Diagram of Test Setup

11.1.1. Block diagram of Test Setup

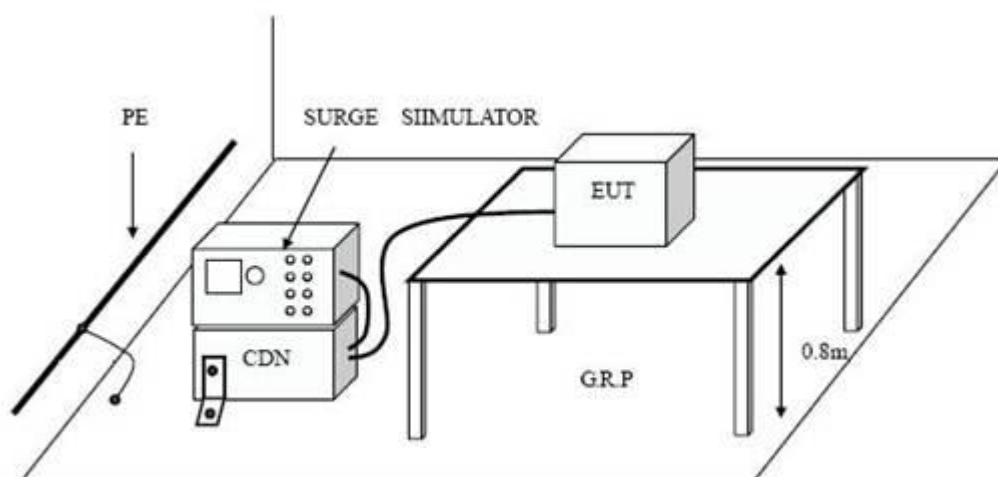

11.2. Test Standard

EN 55024:2010+A1:2015 (EN 61000-4-5:2014)

Severity Level 2 at 1kV for line-line, Severity Level 3 at 2 kV for line-earth

11.3. Severity level and Performance criterion

11.3.1. Severity level

Severity Level	Open-Circuit Test Voltage kV
1	0.5
2	1.0
3	2.0
4	4.0
*	Special

Performance criterion : **B**

11.4. EUT Configuration on Test

The configuration of EUT is listed in Section 4.4.

11.5. Operating Condition of EUT

Setup the EUT as shown in Section 11.1. The operating condition of EUT is listed in section 4.5.

11.6. Test Procedure

- 1) Set up the EUT and test generator as shown on section 11.1.1.
- 2) For line to line coupling mode, provide a 1kV 1.2/50us voltage surge (at open-circuit condition) and 8/20us current surge to EUT selected points.
- 3) At least 5 positive and 5 negative (polarity) tests with a maximum 1/min repetition rate are conducted during test.
- 4) Different phase angles are done individually.
- 5) Repeat procedure 2) to 4) except the open-circuit test voltage change from 1kV to 2kV for line to earth coupling mode test.
- 6) Record the EUT operating situation during compliance test and decide the EUT immunity criterion for above each test.

11.7. Test Results

PASS

Please refer to the following page.

Surge Immunity Test Results

Beide (Shenzhen) Product Service Limited.

Date: Aug. 03, 2018

Applicant : <u>Noor Al Hayat Computer Tr LLC</u>				Test Date : <u>Aug. 03, 2018</u>	
EUT : <u>Power Supply</u>				Temperature : <u>24°C</u>	
M/N : <u>Tortox BX600</u>				Humidity : <u>53%</u>	
Power Supply : <u>AC 230V~, 50Hz</u>				Test Mode : <u>On</u>	
Location	Polarity	Phase Angle	No of Pulse	Pulse Voltage (kV) EN 61000-4-5	Result
L-N	+	0	5	1	Pass
	+	90	5	1	Pass
	+	180	5	1	Pass
	+	270	5	1	Pass
	-	0	5	1	Pass
	-	90	5	1	Pass
	-	180	5	1	Pass
	-	270	5	1	Pass
Remark:					

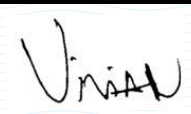
Reviewer: 

12. INJECTED CURRENTS SUSCEPTIBILITY TEST

12.1. Block Diagram of Test Setup

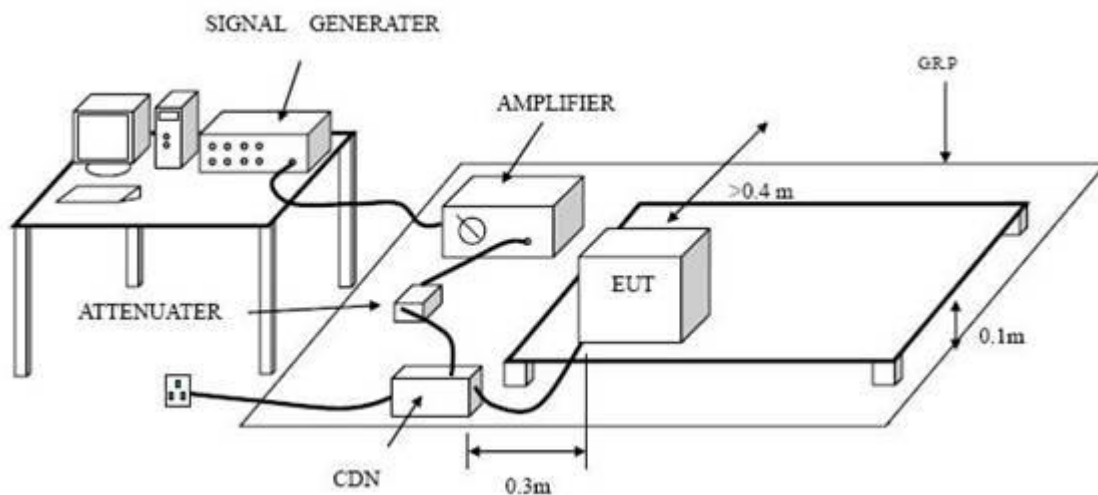

12.2. Test Standard

EN 55024:2010+A1:2015(EN 61000-4-6:2014)
Severity Level 3 at 10V (rms), 0.15 MHz ~ 80 MHz

12.3. Severity Levels and Performance Criterion

12.3.1 Severity level

Level	Field Strength V/m
1.	1
2.	3
3.	10
X	Special

12.3.2 Performance criterion: A

12.4. EUT Configuration on Test

The configuration of EUT is listed in Section 4.4.

12.5. Operating Condition of EUT

12.5.1 Setup the EUT as shown in Section 12.1.

12.5.2 Turn on the power of all equipments.

12.6. Test Procedure

- 1) Set up the EUT, CDN and test generators as shown on Section 12.1.2.
- 2) Let the EUT work in test mode and test it.
- 3) The EUT are placed on an insulating support 0.8m high above a ground reference plane CDN(coupling and decoupling device) is placed on the ground plane about 0.3m from EUT. Cables between CDN and EUT are as short as possible, and their height above the ground reference plane shall be between 30 and 50 mm (where possible).
- 4) The disturbance signal described below is injected to EUT through CDN.
- 5) The EUT operates within its operational mode(s) under intended climatic conditions after power on.
- 6) The frequency range is swept from 150 kHz to 80 MHz using 3V signal level, and with the disturbance signal 80% amplitude modulated with a 1 kHz sine wave.
- 7) The rate of sweep shall not exceed 1.5×10^{-3} decades/s. Where the frequency is swept incrementally, the step size shall not exceed 1% of the start and thereafter 1% of the preceding frequency value.
- 8) Recording the EUT operating situation during compliance testing and decide the EUT immunity criterion.

12.7. Test Results

PASS

Please refer to the following page.

Injected Currents Susceptibility Test Results

Beide (Shenzhen) Product Service Limited

Date: Aug. 03, 2018

Applicant : <u>Noor Al Hayat Computer Tr LLC</u> EUT : <u>Power Supply</u> M/N : <u>Tortox BX600</u> Power Supply : <u>AC 230V~, 50Hz</u> Test Engineer : <u>Jack</u>	Test Date : <u>Aug. 03, 2018</u> Temperature : <u>24°C</u> Humidity : <u>53%</u> Test Mode : <u>ON</u>
---	---

Frequency Range (MHz)	Injected Position	Strength	Criterion	Result
0.15 ~ 80	AC Mains	10V(rms), Unmodulated	A	PASS

Remark : 1. Modulation Signal:1kHz 80% AM	Note:
---	-------

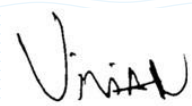
Reviewer: 

13. VOLTAGE DIPS AND INTERRUPTIONS TEST

13.1. Block Diagram of Test Setup

13.1.1. Block diagram of Test Setup

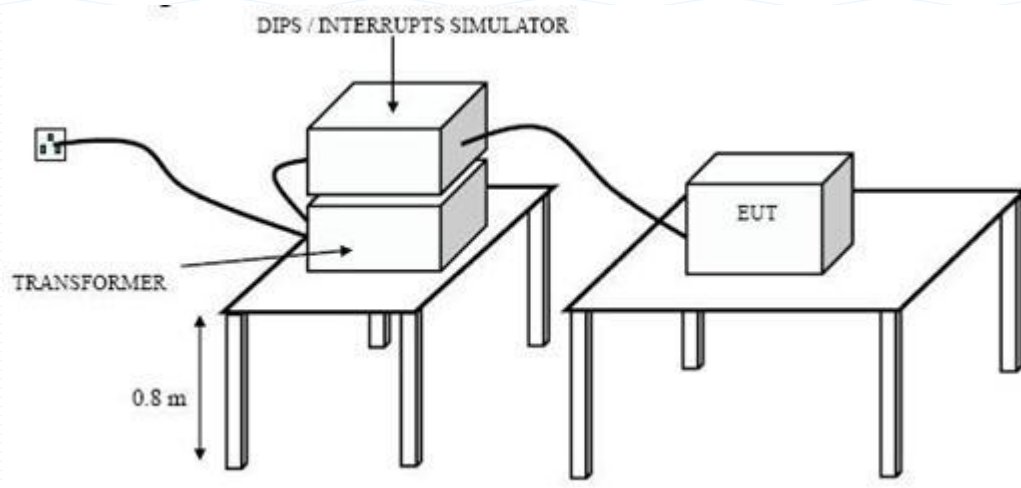

13.2. Test Standard

EN 55024:2010+A1:2015 (EN 61000-4-11:2004)

13.3. Severity level and Performance criterion

13.3.1. Severity level

Test Level %U _T	Voltage dip and short interruptions %U _T	Duration (in period)
0	100	250
0	100	0.5
70	30	25

Performance criterion : B

13.4. EUT Configuration

The configuration of EUT is listed in section 4.4

13.5. Operating Condition of EUT

13.5.1. Setup the EUT as shown on Section 13.1.1.

13.5.2. Turn on the power of all equipments.

13.5.3. Let the EUT work in test mode (ON) and measure it and test it.

13.6. Test Procedure

- 1) Set up the EUT and test generator as shown on section 13.1.1.
- 2) The interruptions is introduced at selected phase angles with specified duration. There is a 3mins minimum interval between each test event.
- 3) After each test a full functional check is performed before the next test.
- 4) Repeat procedures 2 & 3 for voltage dips, only the test level and duration is changed. Record any degradation of performance.

13.7. Test Results

PASS

Please refer to the following page.

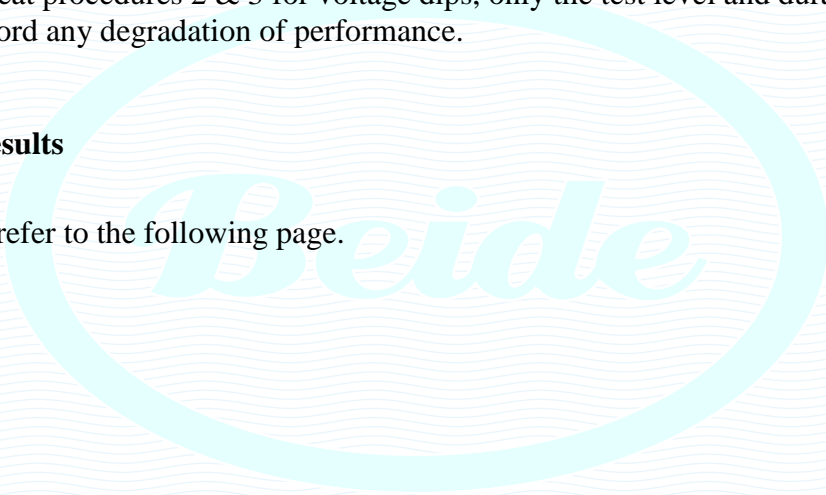

Voltage Dips And Interruptions Test Results

Beide (Shenzhen) Product Service Limited

Date: Aug. 03, 2018

Applicant : <u>Noor Al Hayat Computer Tr LLC</u> EUT : <u>Power Supply</u> M/N : <u>Tortox BX600</u> Power Supply: <u>AC 230V, 50Hz</u>	Test Date : <u>Aug. 03, 2018</u> Temperature : <u>24°C</u> Humidity : <u>53%</u>																														
<input checked="" type="checkbox"/> Single Test Voltage <input type="checkbox"/> Dual Test Voltage																															
Test Model: <u>ON</u>																															
<table border="1" style="width: 100%; border-collapse: collapse; text-align: center;"> <thead> <tr> <th style="width: 15%;">Test Level</th> <th style="width: 20%;">Voltage Dips & Short Interruptions</th> <th style="width: 15%;">Duration (in period)</th> <th style="width: 15%;">Phase Angle</th> <th style="width: 15%;">Criterion</th> <th style="width: 20%;">Result</th> </tr> <tr> <td>% U_T</td> <td>% U_T</td> <td></td> <td></td> <td></td> <td></td> </tr> </thead> <tbody> <tr> <td>0</td> <td>100</td> <td>250P</td> <td>0-360</td> <td>B</td> <td>Pass</td> </tr> <tr> <td>40</td> <td>60</td> <td>25P</td> <td>0-360</td> <td>B</td> <td>Pass</td> </tr> <tr> <td>0</td> <td>100</td> <td>0.5P</td> <td>0-360</td> <td>B</td> <td>Pass</td> </tr> </tbody> </table>	Test Level	Voltage Dips & Short Interruptions	Duration (in period)	Phase Angle	Criterion	Result	% U _T	% U _T					0	100	250P	0-360	B	Pass	40	60	25P	0-360	B	Pass	0	100	0.5P	0-360	B	Pass	Remark: U _T is the rated voltage for the equipment.
Test Level	Voltage Dips & Short Interruptions	Duration (in period)	Phase Angle	Criterion	Result																										
% U _T	% U _T																														
0	100	250P	0-360	B	Pass																										
40	60	25P	0-360	B	Pass																										
0	100	0.5P	0-360	B	Pass																										

Reviewer: _____

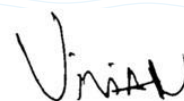

APPENDIX I
(Test Data)

Job No.:		Polarization:	Neutral
Standard:	EN55032	Power Source:	AC 230V~
Test item:	Conduct Test	Temp.(°C)/Hum.(%RH):	24°C/53%RH
EUT:	Power Supply	Date:	2018/08/06
Model:	Tortox BX600	Distance:	

Note:

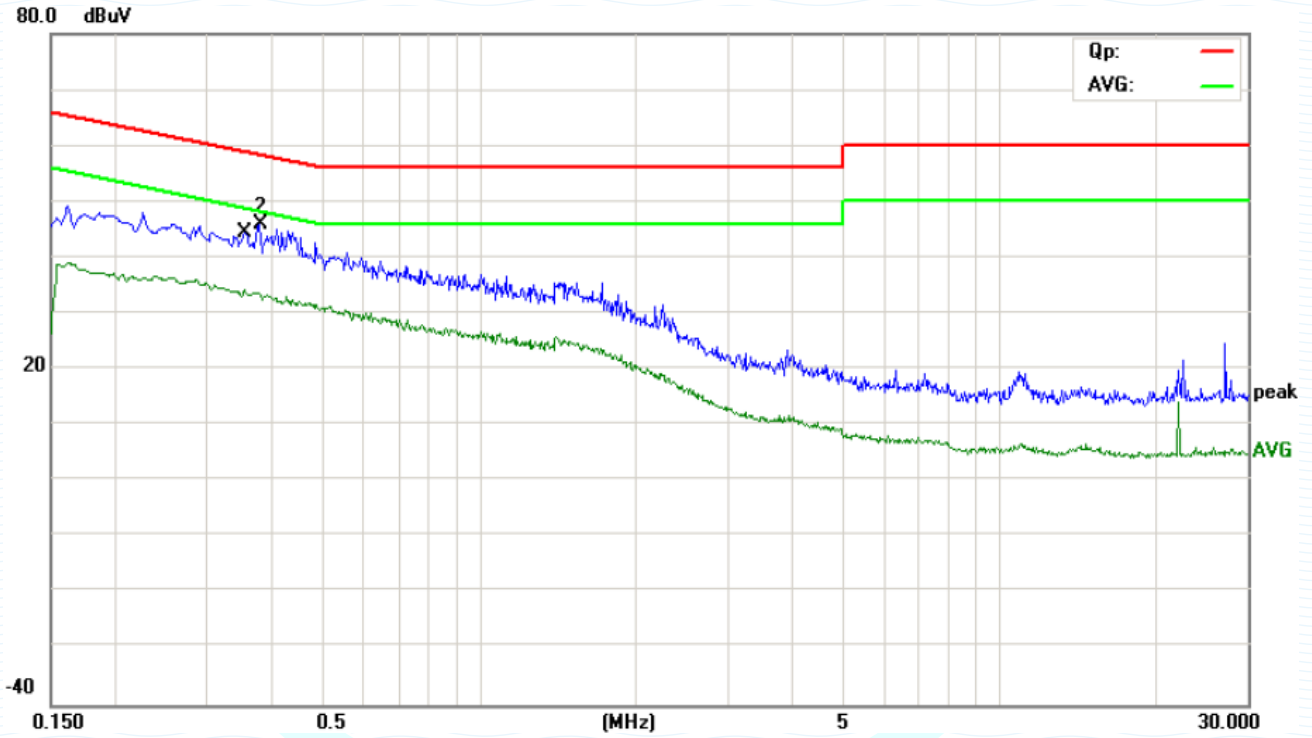

No.	Mk.	Freq. MHz	Reading Level dBuV	Correct Factor dB	Measure- ment dBuV	Limit dBuV	Over dB	Detector	Comment
1		0.3540	24.69	9.59	34.28	48.87	-14.59	AVG	
2	*	0.3780	36.45	9.59	46.04	58.32	-12.28	peak	

Job No.:		Polarization:	Line
Standard:	EN55032	Power Source:	AC 230V~
Test item:	Conduct Test	Temp.(°C)/Hum.(%RH):	24°C/53%RH
EUT:	Power Supply	Date:	2018/08/06
Model:	Tortox BX600	Distance:	

Note:

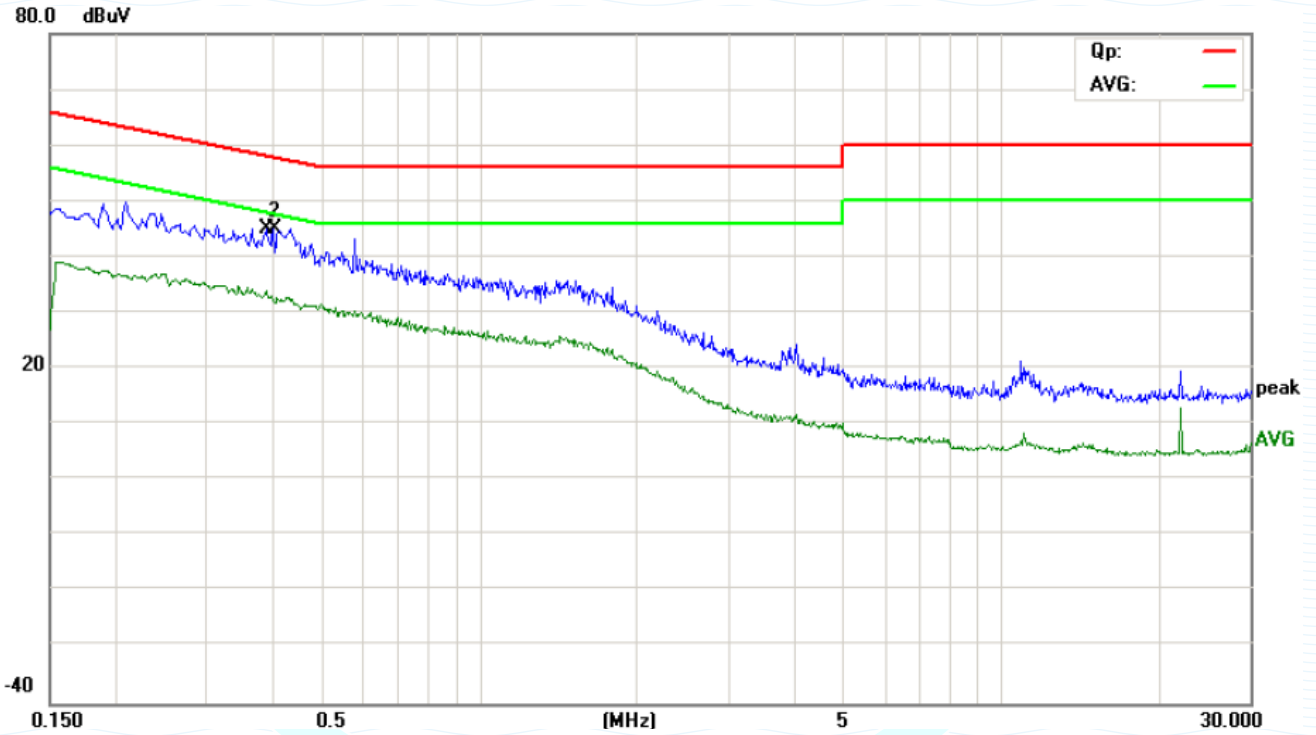

No.	Mk.	Freq. MHz	Reading Level dBuV	Correct Factor dB	Measure- ment dBuV	Limit dBuV	Over dB	Detector	Comment
1		0.3900	24.39	9.59	33.98	48.06	-14.08	AVG	
2	*	0.4020	35.54	9.59	45.13	57.81	-12.68	peak	

Job No.:		Polarization:	Horizontal
Standard:	EN55032	Power Source:	AC 230V~
Test item:	Radiation Test	Date:	2018/08/06
Temp.(°C)/Hum.(%RH):	24°C/53%RH		
EUT:	Power Supply		
Model:	Tortox BX600	Distance:	3m

Note:

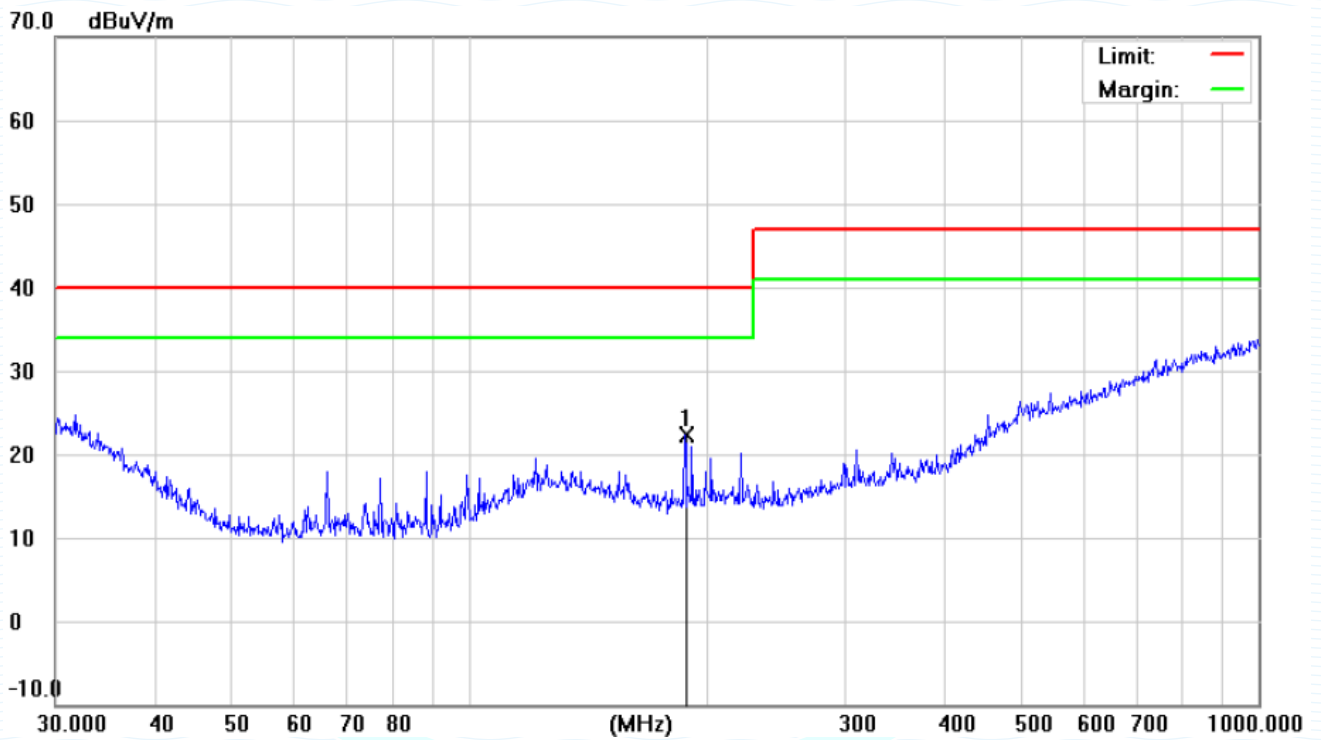

No.	Mk.	Freq.	Reading Level	Correct Factor	Measurement	Limit	Over	Antenna Height	Table Degree		
		MHz	dBuV	dB	dBuV/m	dBuV/m	dB	Detector	cm	degree	Comment
1	*	187.7530	10.52	11.83	22.35	40.00	-17.65	QP			

Job No.:		Polarization:	Vertical
Standard:	EN55032	Power Source:	AC 230V~
Test item:	Radiation Test	Date:	2018/08/06
Temp.(°C)/Hum.(%RH):	24°C/53%RH	Distance:	3m
EUT:	Power Supply		
Model:	Tortox BX600		
Note:			

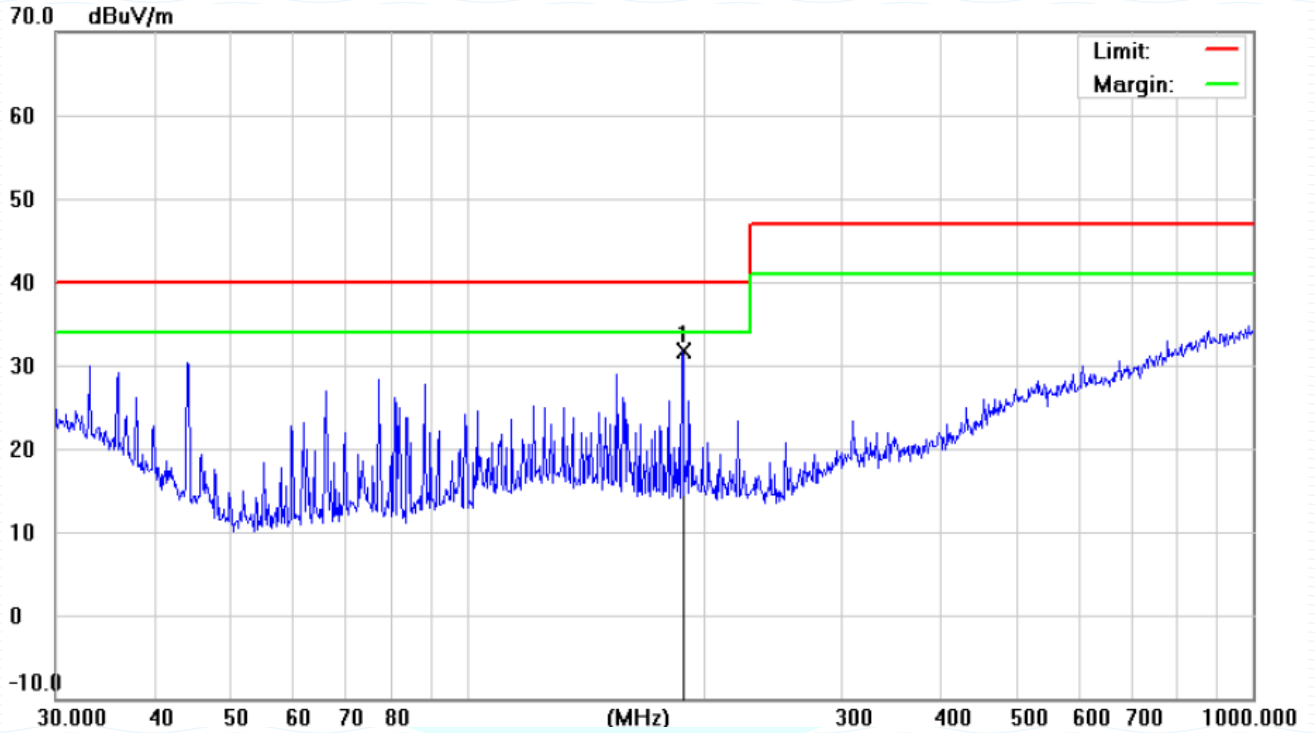

No.	Mk.	Freq.	Reading Level	Correct Factor	Measurement	Limit	Over	Antenna Height	Table Degree		
		MHz	dBuV	dB	dBuV/m	dBuV/m	dB	Detector	cm	degree	Comment
1	*	187.7530	19.85	11.83	31.68	40.00	-8.32	QP			

APPENDIX II
(EUT Photos)

Beide

Figure 1
APPEARANCE OF EUT



Figure 2
APPEARANCE OF EUT

